

INTRODUCTION

Thank you for choosing an HK Instruments DPI series electronic differential pressure switch. The DPI series is intended for use in commercial environments. It combines the advantages of an electronic differential pressure switch (on-off relay) and a multi-functional differential pressure transmitter to meet your job requirements.

The DPI series is comprised of the DPI±500 with bi-directional measurement ranges from ±100 to ±500 Pa and the DPI2500 with measurement ranges from 100 to 2500 Pa.

All DPI series devices include one relay, display, manual pushbutton auto-zero and span point calibration. Optional features include a second relay and autozero calibration.

APPLICATIONS

DPI series devices are commonly used in HVAC/R systems for:

- fan, blower and filter monitoring
- staircase pressure monitoring and alarm
- pressure monitoring in cleanrooms
- boiler pressure monitoring and alarm

SPECIFICATIONS

Performance

Accuracy:

±0.7 % (±1.5 % initial)

%/FS from highest pressure range including:

general accuracy, temperature drift, linearity, hysteresis, and repetition error.

Long term stability:

Typical 1 year

With autozero: ±1 Pa

Without autozero: ±8 Pa

Overpressure:

Proof pressure: 25 kPa

Burst pressure: 30 kPa

Zero point calibration:

Automatic with autozero(-AZ) circuit or

Manual via menu

Response time:

0.5–10 s, selectable via menu

Technical Specifications

Media compatibility:

Dry air or non-aggressive gases

Measuring units:

Pa, kPa, mmWC, inWC, mbar selectable via menu

Measuring element:

Piezoresistive

Environment:

Operating Temperature:

Without autozero : -10...50 °C

With autozero: -5...50 °C

Storage temperature: -20...70 °C

Humidity: 0 to 95 % rH, non condensing

Physical

Dimensions:

Case: 89 x 86.5 x 37.1 mm

Weight:

150 g

Mounting:

Case: 2 each 4.3 mm holes

Lid: 2 each 4.3 mm holes

Materials:

Case: ABS

Lid: PC

Protection standard:

IP54

Touch sensitive buttons on the lid:

Menu, Back, OK, down arrow, up arrow

Display:

3 1/2 digit LCD backlit display

Size: 46.0 W x 14.5 H mm

Electrical connections:

n/out:

Terminal block (24 V, GND, 0–10 V)

Wire: 12–24 AWG (0.2–1.5 mm²)

Relay 1:

Terminal block (NC, COM, NO)

Wire: 12–24 AWG (0.2–1.5 mm²)

Relay 2:

Terminal block (NC, COM, NO)

Wire: 12–24 AWG (0.2–1.5 mm²)

Cable entries:

Strain relief: M16 & M20

Knockout : 16 mm

Knockout : 20 mm

Pressure fittings:

5.2 mm barbed brass

+ High pressure

– Low pressure

Electrical

Circuit: 3-wire (24 V, GND, 0–10 V)

Input:

Without autozero: 21–35 VDC / 24 VAC, ±10 %

With autozero: 24 VAC or VDC, ±10 %

Output:

Analog: 0–10 V

Relay 1: 250 VAC / 30 VDC / 6 A

Relay 2: 250 VAC / 30 VDC / 6 A

Resistance minimum: 1 kΩ

Current consumption:

35 mA + relays (7 mA each) + AZ circuit (20 mA)

+ 0–10 V output (10 mA)

Conformance

Meets requirements for CE marking:

EMC Directive 2004/108/EC

RoHS Directive 2002/95/EC

LVD Directive: 2006/95/EC



WARNING

- READ THESE INSTRUCTIONS CAREFULLY BEFORE ATTEMPTING TO INSTALL, OPERATE OR SERVICE THIS DEVICE.
- Failure to observe safety information and comply with instructions can result in PERSONAL INJURY, DEATH AND/OR PROPERTY DAMAGE.
- To avoid electrical shock or damage to equipment, disconnect power before installing or servicing and use only wiring with insulation rated for full device operating voltage.
- To avoid potential fire and/or explosion do not use in potentially flammable or explosive atmospheres.
- Retain these instructions for future reference.
- This product, when installed, will be part of an engineered system whose specifications and performance characteristics are not designed or controlled by HK Instruments. Review applications and national and local codes to assure that the installation will be functional and safe. Use only experienced and knowledgeable technicians to install this device.



SCHEMATICS

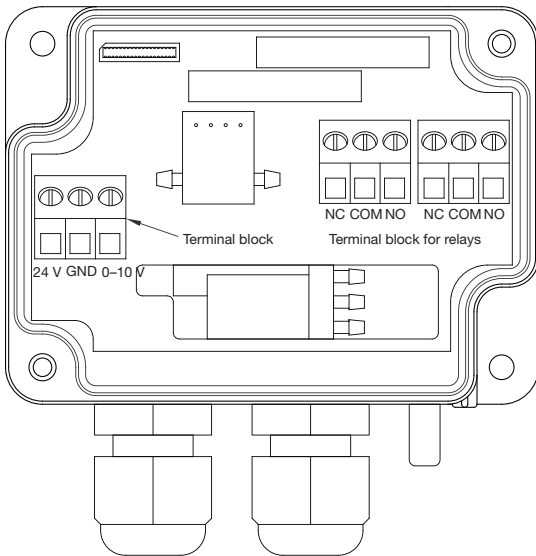

DIMENSIONAL DRAWINGS

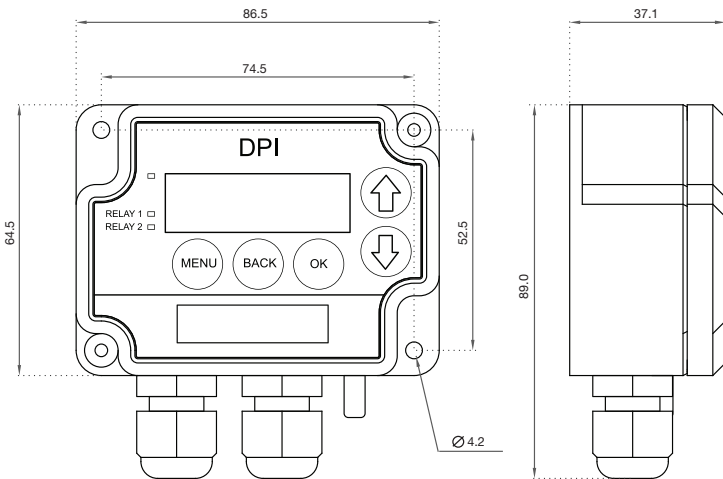

INSTALLATION

- 1) Mount the device in the desired location (see step 1).
- 2) Open the lid and route the cable(s) through the strain relief(s) and connect the wires to the terminal block(s) (see step 2).
- 3) The device is now ready for configuration.

⚠ WARNING! Apply power only after the device is properly wired.

STEP 1: MOUNTING THE DEVICE

- 1) Select the mounting location (duct, wall, panel).
- 2) Use the device as a template and mark the screw holes.
- 3) Mount with appropriate screws (not included).

Figure 1a - Surface mounting

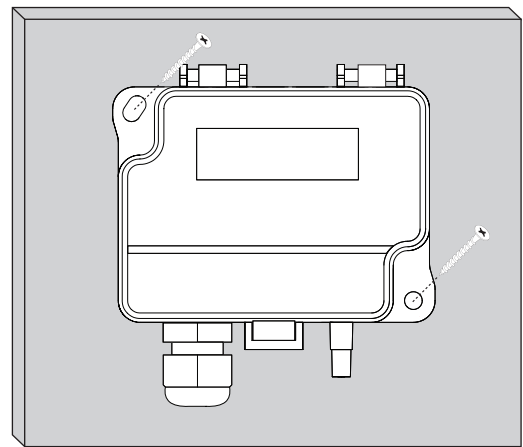

Figure 1b - Mounting orientation

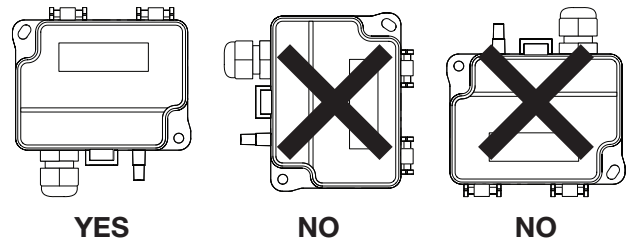
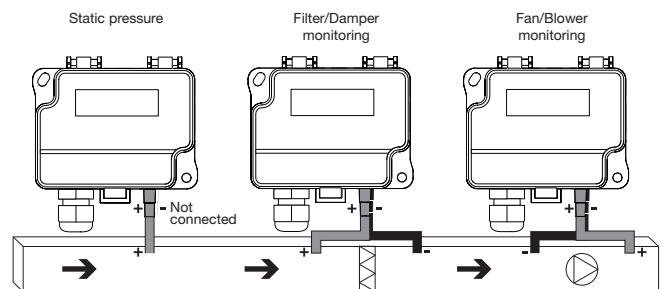

Figure 1c - Application connections



STEP 2: WIRING DIAGRAMS

For CE compliance, a properly grounded shielding cable is required.

- 1) Unscrew the strain relief and route the cable(s). Use separate strain relief for the 0–10 V output cable and the relay cable(s).
- 2) Connect the wires as shown in figure 2a and 2b.
- 3) Tighten the strain relief.

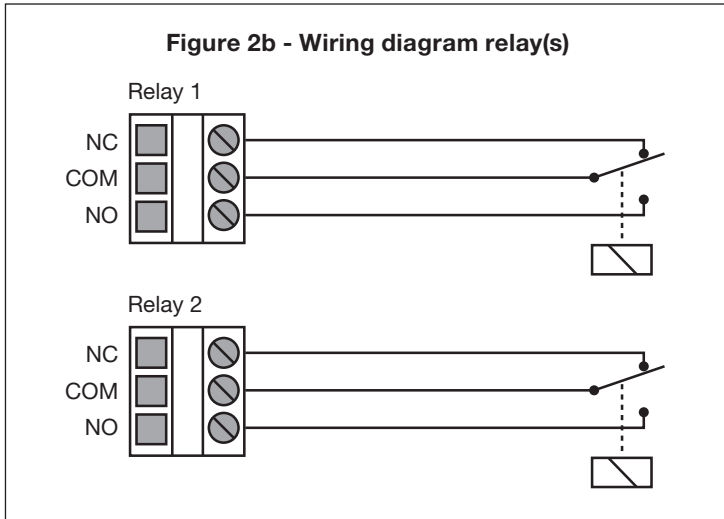
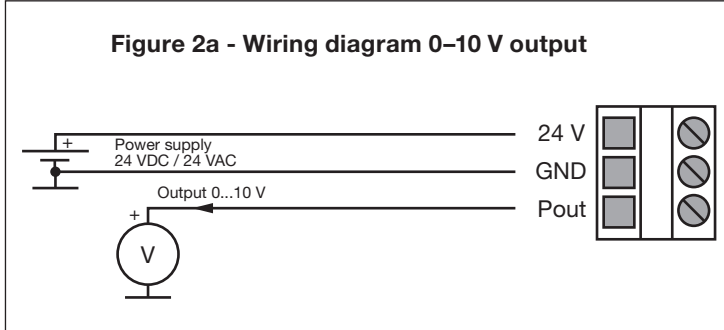

CONFIGURATION CONTINUED

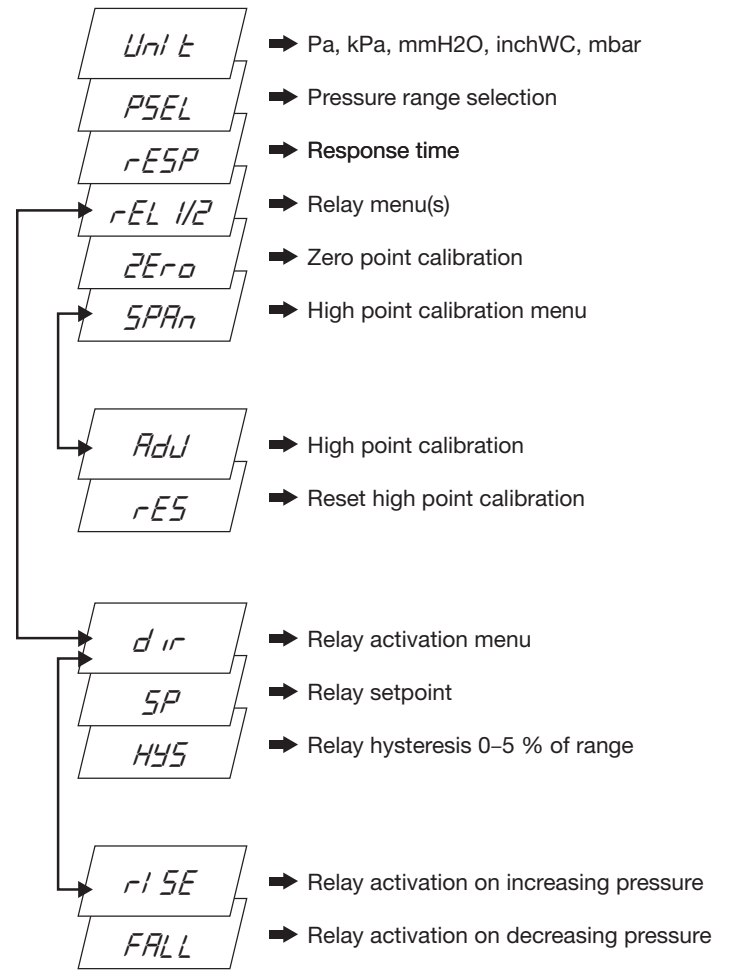

STEP 3: CONFIGURATION

- 1) Select the desired measurement unit.
 - 2) Select the desired measurement range.
 - 3) Select the desired response time.
 - 4) Configure the relay(s).
 - 5) Zero the device.
 - 6) Calibrate the span point.
 - 7) Connect the pressure tubes. Connect positive pressure to port labeled "+" and negative pressure to port "-".
- The device is now ready to be used.

With the **MENU** button you can enter the menu by pressing the button for 3 seconds. You can exit the menu without making any changes.

With the **BACK** button you can return without making changes.

With the **OK** button you can open new options or confirm changes and return to previous display.

With the **↑** **↓** buttons you can scroll the menus.

STEP 4: ZEROING THE DEVICE

To zero the device two options are available:

- 1) Manual Pushbutton zero point calibration
- 2) Autozero calibration

Does my transmitter have an autozero calibration? See the product label. If it shows -AZ in the model number, then you have the autozero calibration.

- 1) Manual Pushbutton zero point calibration

NOTE: Supply voltage must be connected at least one hour prior to zero point adjustment.

- a) Disconnect both pressure tubes from the pressure ports labeled + and –.
- b) Push both arrow buttons on top of the lid shortly or go to configuration menu and select “Zero”.
- c) The zeroing of the device will proceed automatically when the green led on top of the lid turns off and “Zero” text followed by a counter from 3 to 0 seconds appears on the display. The zeroing is complete when the green led turns on again.
- d) Reinstall the pressure tubes ensuring that the High pressure tube is connected to the port labeled +, and the Low pressure tube is connected to the port labeled –.

NOTE: The zero point should be calibrated via manual autozero, one hour after installation and at least every 12 months during normal operations.

- 2) Autozero calibration

If the device includes the optional autozero circuit, no action is required.

Autozero calibration (-AZ) is an autozero function in the form of an automatic zeroing circuit built into the PCB board. The autozero calibration electronically adjusts the transmitter zero at predetermined time intervals (every 10 minutes). The function eliminates all output signal drift due to thermal, electronic or mechanical effects, as well as the need for technicians to remove high and low pressure tubes when performing initial or periodic transmitter zero point calibration. The autozero adjustment takes 4 seconds after which the device returns to its normal measuring mode. During the 4 second adjustment period, the output and display values will freeze to the latest measured value.

Transmitters equipped with the autozero calibration are virtually maintenance free.

WARRANTY POLICY

The seller is obligated to provide a warranty of 24 months for the delivered goods regarding material and manufacturing. The warranty period is considered to start on the delivery date of the product. If a defect in raw materials or a production flaw is found, the seller is obligated, when the product is sent to the seller without delay or before expiration of the warranty, to amend the mistake at his/her discretion either by repairing the defective product or by delivering free of charge to the buyer a new flawless product and sending it to the buyer. Delivery costs for the repair under warranty will be paid by the buyer and the return costs by the seller. The warranty does not comprise damages caused by accident, lightning, flood or other natural phenomenon, normal wear and tear, improper or careless handling, abnormal use, overloading, improper storage, incorrect care or reconstruction, or changes and installation work not done by the seller or his/her authorized representative. The selection of materials for devices prone to corrosion is the buyer's responsibility, unless otherwise is legally agreed upon. Should the manufacturer alter the structure of the device, the seller is not obligated to make comparable changes to devices already purchased. Appealing for warranty requires that the buyer has correctly fulfilled his/her duties arisen from the delivery and stated in the contract. The seller will give a new warranty for goods that have been replaced or repaired within the warranty, however only to the expiration of the original product's warranty time. The warranty includes the repair of a defective part or device, or if needed, a new part or device, but not installation or exchange costs. Under no circumstance is the seller liable for damages compensation for indirect damage.